

OWNER'S MANUAL

OPERATION & SERVICE PARTS

MAXJET SERIES



OPERATIONS AND SERVICE MANUAL

FOR

MODEL MJ7260

SERIAL#: MJ16051803

866-540-7575

CONTENTS

- **INSTALLATION**
- **START UP**
- **OPERATING INSTRUCTIONS**
- **CHEMICAL SELECTION**
- **CLEANING TIPS**
- **GENERAL MAINTENANCE**
- **TROUBLESHOOTING**
- **SERVICE PARTS LIST**
- **HOW TO REPLACE COMMON PARTS**
- **ELECTRICAL SCHEMATICS**
- **WARRANTY POLICY**
- **TEST SHEET**

Installation

1. **UNPACKING:** If any damage is found, notify your carrier immediately and save all crating materials for the carrier's inspector to examine. Failure to promptly report damage could result in denial of your claim.

If no damage is found, remove the banding that secure the machine to the pallet. Remove the machine from the pallet. Be careful not to damage the casters mounts on the underside. Install the four steel casters provide in the box inside the washer cabinet.

2. **LOCATIONS:** Your jet washer will generate hot water vapor. **Choose a location where the hot water vapor cannot harm anything in the surrounding area.**

The process of removing wet parts from the cabinet will inevitably result in some wash solution spilling onto the floor, possibly causing slippery conditions. **IF YOUR FLOOR IS SMOOTH, PLACE ONE OR MORE TRACTION MATS AROUND THE MACHINE AND AVOID PLACING THE WASHER NEAR A WALKWAY.**

If your washer is permanently wired, keep in mind that **at least 30" is needed for service behind the machine.** If you want the machine to be against a wall, plan your various service connections so that they can be easily disconnected. The site chosen must be level for proper turntable rotation and for the optimum water level in the tank. Your Hot Jet washer is not portable once filled with water. Once in place level the unit from front to back and from side to side by shimming the frame and legs.

3. **MACHINE POWER HOOK-UP:** **If you do not have a lock out breaker box on your machine one should be installed between the power source and the washer electrical panel. A licensed electrician is advised for performing the hook ups.**

Start Up

1. **Please read this entire manual before attempting to install your MaxJet Spray Washer. You will be less likely to make mistakes if you have a grasp of the "whole picture."**
2. **The vibration in route could have loosened one or more wire connections.** Before connecting power, remove cover off of the electrical box and tighten all connections. Your machine utilizes high voltage. Use the services of a licensed electrician or qualified in house people for all electrical work.
3. **The heating element(s) and the pump/motor will be ruined if they are turned on when there is no water in the tank.** Therefore, don't turn on electric power to the machine unless the pump and heat controls are off or unless the tank is filled with water to the proper level.
4. **INCOMING PLUMBING CONNECTIONS: If your machine has the automatic water fill option, you need to connect a fresh water line to the unit.** There is a 1/2" solenoid valve for the auto-fill.
5. **If your jet washer is made with mild steel and it will rust unless you use the correct detergent and follow the correct start-up procedure.** Specification for Quality Systems CWC 100 Spray Washer Detergent are provided and this or similar detergent should be used. Make sure the brand you are using is safe on mild steel and has an adequate concentration of rust inhibitors. When installing the unit, don't fill the tank with water unless you have the time needed to heat the water to 140° to 175° F, add the detergent, and run the wash cycle for at least one (1) hour to coat the steel with rust inhibitor. Again, read this entire manual before starting the installation so that you know what is involved.
6. **Do not use any petroleum base chemical or solvent or any flammable products in the washer.**
7. **The heating element(s) or gas train and pump/motor can be damaged if the water level drops too low.** Even if your machine has the optional "low water shut-off or automatic water fill", check the water level daily when in use. The proper water level is to the top of the filter tray in the bottom of the cabinet. The water level will drop about one inch when pump is started.
8. **Clean the filter debris tray daily.**
9. **If you are not using Quality Systems CWC 100 Spray Washer Detergent, be sure the detergent is suitable for your jet washer and application:**
 - Contains an adequate level of rust inhibitors
 - Low foaming/designed for jet washers
 - Safe for the metals you will be cleaning
 - See "Chemical Selection"
10. **Cleaning will be poor and the heating element(s) and pump/motor may be damaged if the tank and spray manifolds are not cleaned according to instructions.**
11. **On three (3) phase washers, your electrician must check the pump/motor rotation.** For a brief interval, run the pump/motor to check rotation. The motor will be damaged if you run it backwards for an extended period. You can check rotation without having water in the tank but don't turn the pump back on until water is added.

OPERATIONS TEST

Before turning on the electrical power to the machine, make sure the wash timer or sequencer in the "off mode. If your machine has a power cord, turn the power on and off with your circuit breaker. Read "Start Up" numbers 3, 4 and 6 about the proper water level and the potential for rust. Don't start this test unless you can spend 2 to 3 hours to heat the water, add detergent, and run the wash cycle for 1½ hour.

1. Open the door to the cabinet.
2. Fill the tank with water so that the water level is in accordance start up instructions. (To the top of chip tray located in the bottom of the cabinet)
3. The thermostat is factory preset for most applications. The recommended temperature is 175 F. Turn on power to the machine using timers.
4. Set the 7 day or 0-12 heat timer. Make sure they are in a run time setting and switch is on. Leave the heat on for the balance of this test.

Operating Tips

1. **Assign the responsibility of your jet washer to one person to avoid abuse and neglect.** This person will check the water level every day; have the tank cleaned out periodically, etc.
2. **Due to evaporation and drag-out, you will need to add water to the tank every day washer is used.** The importance of the water level has been stressed throughout this manual (read "Precautions" numbers 3 and 6).
3. **Turn on the heat circuit with the circuit breaker or with the optional 7-day time lock. Allow one to one and a half (1.5) hours to heat the solution from 70s F to the operational temperature range of 160° to 180° F.** If your washer has the optional 7-day timer and you want the washer operational at 8:00 AM for example, set the clock to come on at 6:30 AM.
4. **Hint - To save energy, turn the heat off one (1) hour before you stop using the machine.** The water will stay hot enough for effective cleaning.
5. **Do not add detergent or start the wash cycle until the water is hot.** Otherwise, the solution may foam.
6. **Add the detergent according to the supplier's instructions.** You can either pour the detergent directly into the tank or into spraying floor area. Run at least a 15-minute wash cycle to thoroughly mix the detergent in solution. Weigh the detergent to determine an accurate volume measure. Don't make the common mistake of using a one pound coffee container thinking it also holds a pound of detergent. Your solution can be used until it is too dirty to clean effectively. You may have to add small amounts of detergent when you add water to keep at maximum cleaning strength.

In the future, you may want to increase or reduce the detergent concentration until you find the ideal concentration for your application. If the detergent is leaving an excessive residue on the parts, reduce the concentration. Consult the factory if you cannot obtain the desired results. In some cases, the hardness of your water could create a problem.

Chemical Selection

The detergent is responsible for as much as 50% of the overall cleaning results. Thus, the cleaning results you get from your MAXJET Hot Jet Spray Washer will be as good as, or as bad as the detergent you select. Make sure the detergent is:

- (1) Safe to use in a mild steel cabinet if this is your construction;
- (2) Safe to use on the different types of parts you will be cleaning and;
- (3) Low foaming when used in a jet washer.

Quality Systems offers a proven product that is safe on aluminum parts as well as steel. For time-tested results, request #229 Jet Spray Detergent.



#229 JET SPRAY DETERGENT

GENERAL DESCRIPTION

A non-forming, rust inhibited, powdered) alkaline) cleaning compound specially formulated for use in high flow jet spray parts washer systems. Ideal for removing hydrocarbon based grease and oils. Aluminum safe as well as other ferrous alloys. Emulsifies grease and oils and rinses completely. Packaged in 40 lbs boxes, 400 lbs drums.

SPECIALLY FORMULATED FOR RECIRCULATING CABINET WASHER

High-pressure washer and jet spray cabinet systems. Use for cleaning and degreasing parts soiled with hydrocarbon based contaminates, dirt, and other debris. If foaming occurs be sure water is at least 150°F. A defoaming agent it may be needed for certain gear oils, food machine lubricants, and certain greases. Concentration will vary with grease and type of contaminates.

GENERAL CABINT WASHER APPLICATION RATES

Add 5-7 lbs, or 2-3 quarts dry mix, for each 50 gallons of reservoir capacity. Very heavy grease build up may require 1-2 pounds additional product. QS detergent dissolves best in water at 140 degree F and up. Make sure water is at this temperature prior to running pump or foaming may occur. Make up detergent may be needed between changes to insure proper cleaning.

#229 FOR HIGH PRESSURE CLEANING

Dissolving 5 pounds of #229 in 5-gallon hot water can make a general-purpose economical cleaning product. Pour the mixture in clean 55-gallon drum and fill with water.

General Cleaning Tips

If parts are caked with heavy dirt or excessive grease build up you will want to scrape the bulk of it off before placing in washer. This will allow the hot soap and water to penetrate and break down the oils. Remember all the debris that goes into the washer will eventually have to be cleaned out.

When loading a batch of parts, space the parts so that the spray can hit all surfaces. Always try to keep the load centered on the turntable ie. If a part has blind holes or pockets, try to have these orifices face downward so that the part doesn't hold water. Long pan shapes are best cleaned in a vertical position. Secure to the tee bar to hold in position while cleaning. For the best flash drying, remove the parts right after the wash cycle while parts are still hot. The parts will not dry inside the machine due to the hot water vapor and the steam can remove the rust inhibitor causing rusting if left over night.

In the first couple of days of operation, observe the chip tray after every wash cycle to determine how often it will need to be cleaned. Clean the filter tray at least once a day.

**QUALITY SYSTEMS
SHAWNEE MISSION, KS
866-540-7575**

General Maintenance

FOR DAILY USE

1. Check water level. The proper level is to the top of the chip basket
2. If equipped, inspect and service as required the in-line strainer that is installed between the pump and spray manifolds.
3. Clean any nozzles that are clogged. If clogging persists, clean the filter basket, tank, and/or spray manifolds.
4. Clean out the filter basket.
5. If you have optional "Total Solids" bag filter, check pressure reading and clean or replace filters if there is appreciable pressure drop across the filters.
6. Clean and solution spilled onto the painted surfaces of the machine by wiping down with fresh water.
7. Run the oil skimmer - preferably after the water has set quiet over night. The manual skimmer timer has a maximum time of 15 minutes and this is sufficient to remove oil daily. Optional 7- Day time can be set to run in off hours as desired. Collected oil may be place in your waste oil tank for disposal.

WEEKLY OR AS NEEDED

1. Lubricate the turntable bearing with water resistant #2 lithium grease.
2. Check the sludge level in the tank. If build up is greater than one inch, clean out the tank. It is important that sludge does not encapsulate the heat elements.

TANK CLEAN OUT TIPS

1. Cut power to the machine or make sure pump and heat circuits are off.
2. Drain tank following government regulations. Use a hose to flush tank sediment towards the drain located on side. Tank access can be gained by removing front cover and chip tray.
3. Heat and charge solution with detergent.

Troubleshooting

1. Nothing Works

- Breaker switch is off.
- (7-day timer if equipped) is in non-run position.

2. Cabinet is Rusting Inside

- Wrong detergent – Replace solution with detergent containing proper rust inhibitor.
- Water is allowed to steam without running pump to keep the inside coated with rust inhibitor. Only head on days that machine will be operated.
- Stop rusting by running higher concentration of detergent and using machine for several hours.

3. Foaming

- Wrong detergent may have been used.
- The pump was started with cold solution.
- Solution concentration low, add more detergent, or water level is too low.
- Food machine grease or gear oil may require a defoaming agent.

4. Solution Not Hot

- One or more heating elements are bad.
- 7 – Heat Timer is not in a run position.

5. Turntable- Does Not Rotate or Slow Rotation

- Drive motor is bad. The Granger part number is provided. The replacement instructions are listed in the repair section.
- Make sure you have not exceeded load capacity. A large part could be caught on inside of the cabinet. Check and rearrange parts if needed.

6. Oil Skimmer Wheel Does Not Turn

- Wheel Plate loose on shaft - tighten.
- Skimmer Timer is bad – check and replace.

NEED MORE HELP – Call

QUALITY SYSTEMS - 866-540-7575

MAXJET SERVICE PARTS

CONTACT: Quality Systems – 913-362-6131
qualitysystems@earthlink.net

FRONT LOAD MJ7260 SUPER DUTY WASHER SERVICE PARTS

- **P/N 11032NS-A20.3** 20HP/3PH VERTICAL SEALLESS GUSHER PUMP
- **P/N 1731** WATLOW THERMOSTAT
- **P/N 1800** 60 MINUTE SPRING WOUND WASH TIMER
- **P/N 1800.8** 12 HOUR SPRING WOUND HEAT TIMER
- **P/N 6102-A** PUMP SUCTION SCREEN
- **P/N 2006** SPRAY JET 1565 NOZZLES ¼" (11 EA. REQ'D. FOR TOP OF SPRAY BAR)
- **P/N 3040** SPRAY JET 3040 NOZZLES ¼" (35 EA. REQ'D. FOR BOTTOM & SIDES OF SPRAY BAR)
- **P/N 12203.1** TURNTABLE DRIVE GEARMOTOR
- **P/N 14608.2** GEARMOTOR SHAFT ARBOR
- **P/N 14304** TURNTABLE DRIVE GEAR
- **P/N 4842-A** 4 BOLT HUB/BEARING ASSEMBLY
- **P/N 1914** TURNTABLE JOG SWITCH
- **P/N 12219** 2 WIRE OIL SKIMMER GEARMOTOR
- **P/N 14608.2** OS GEARMOTOR SHAFT ARBOR
- **P/N 14622** 12" OIL SKIMMER WHEEL
- **P/N 14630** OIL SKIMMER ARM/TRAY
- **P/N 14613** OIL SKIMMER WIPER BLADES
- **P/N 1911** OIL SKIMMER TOGGLE SWITCH
- **P/N 1911** HEATER TOGGLE SWITCH
- **P/N 8078** DOOR LATCH
- **P/N 1914** DOOR SAFETY SWITCH
- **P/N 3005** LOW WATER SHUT-OFF SWITCH
- **P/N F1** ROSEDALE BAG FILTER SYSTEM
- **P/N 6016.1** 100 MICORN FILTER SOCKS
- **P/N 9979.7** F1 O-RING

**6X546 Wash Cycle
Timer 0-60 minutes**



3M096 Oil Skimmer Motor



**2E 269 for 0-15
Oil Skimmer Timer
(Not Pictured)**

4Z518 Turntable Drive Motor



3ZN05 Gear Motor Shaft



2X894 Door Safety Switch

5E658 Door Latch



Heater Replacement Instructions

- 1. TURN BREAKERS OFF AND UNPLUG WASHER.**
- 2. DRAIN TANK.**
- 3. REMOVE SCREWS HOLDING WIRES TO OLD HEATER ELEMENT.**
- 4. REMOVE OLD HEATER ELEMENT.**
- 5. INSTALL GASKET ON NEW HEATER ELEMENT THREADS.**
- 6. APPLY PIPE DOPE ON REMAINING NEW HEATER ELEMENT THREADS.**
- 7. SCREW NEW HEATER ELEMENT(S) IN UNTIL GASKET CONNECTS WITH TANK COUPLER. TIGHTEN ONE HALF TO ONE TURN-DO NOT OVERTIGHTEN!**
- 8. REINSTALL NEW HEATER ELEMENT WIRES AND SCREWS.**
- 9. FILL TANK AND CHECK FOR LEAKS.**
- 10. REPLACE BACK COVER.**
- 11. FOLLOW WASHER OPERATING INSTRUCTIONS.**

Thermostat Replacement Instructions

- 1. TURN BREAKERS OFF AND UNPLUG WASHER.**
- 2. REMOVE BACK COVER.**
- 3. REMOVE TWO WIRES FROM OLD THERMOSTAT.**
- 4. REMOVE TWO NUTS RETAINING OLD THERMOSTAT.**
- 5. REMOVE OLD THERMOSTAT.**
- 6. REINSTALL NEW THERMOSTAT.**
- 7. REPLACE TWO NUTS ON NEW THERMOSTAT. TIGHTEN NEW THERMOSTAT UNTIL IT WILL NOT MOVE-DO NOT OVERTIGHTEN!**
- 8. REINSTALL TWO WIRES TO NEW THERMOSTAT.**
- 9. REPLACE BACK COVER.**
- 10. FOLLOW WASHER OPERATING INSTRUCTIONS.**

Skimmer Gear Motor Replacement

- 1. TURN BREAKER OFF AND UNPLUG WASHER.**
- 2. REMOVE OIL SKIMMER WIPERS.**
- 3. REMOVE OIL SKIMMER WHEEL AND ARBOR BY LOOSENING OUTSIDE NUT.**
- 4. LOOSEN SET SCREW THAT ATTACHES ARBOR TO OLD OIL SKIMMER GEARMOTOR.**
- 5. REMOVE OIL SKIMMER WHEEL AND ARBOR ASSEMBLY.**
- 6. REMOVE OIL SKIMMER GEARMOTOR MOUNTING COVER.**
- 7. DISCONNECT RED & WHITE WIRES FROM OLD OIL SKIMMER GEARMOTOR BY REMOVING SCREWS AND SPACER WASHERS.**
- 8. INSTALL NEW OIL SKIMMER GEARMOTOR BY CONNECTING RED & WHITE WIRES WITH SCREWS AND SPACER WASHERS.**
- 9. REINSTALL OIL SKIMMER GEARMOTOR MOUNTING COVER.**
- 10. REINSTALL OIL SKIMMER WHEEL AND ARBOR ASSEMBLY.**
- 11. TIGHTEN SET SCREW THAT ATTACHES ARBOR TO NEW OIL SKIMMER GEARMOTOR.**
- 12. REINSTALL OIL SKIMMER WHEEL AND ARBOR BY TIGHTENING OUTSIDE NUT.**
- 13. REINSTALL OIL SKIMMER WIPER.**
- 14. FOLLOW WASHER OPERATING INSTRUCTIONS.**

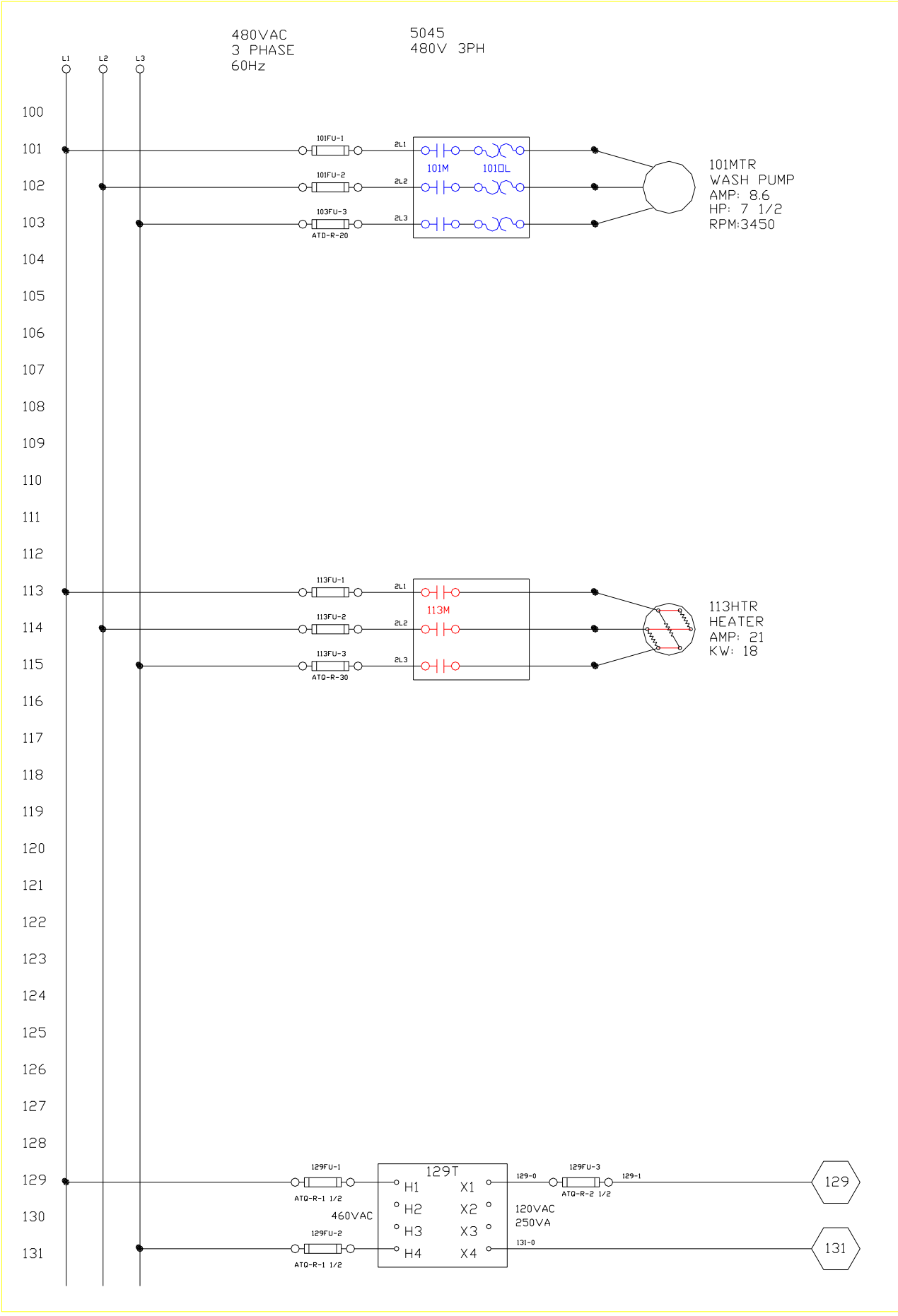

5045
480V 3PH

129 129-1

131-0 131

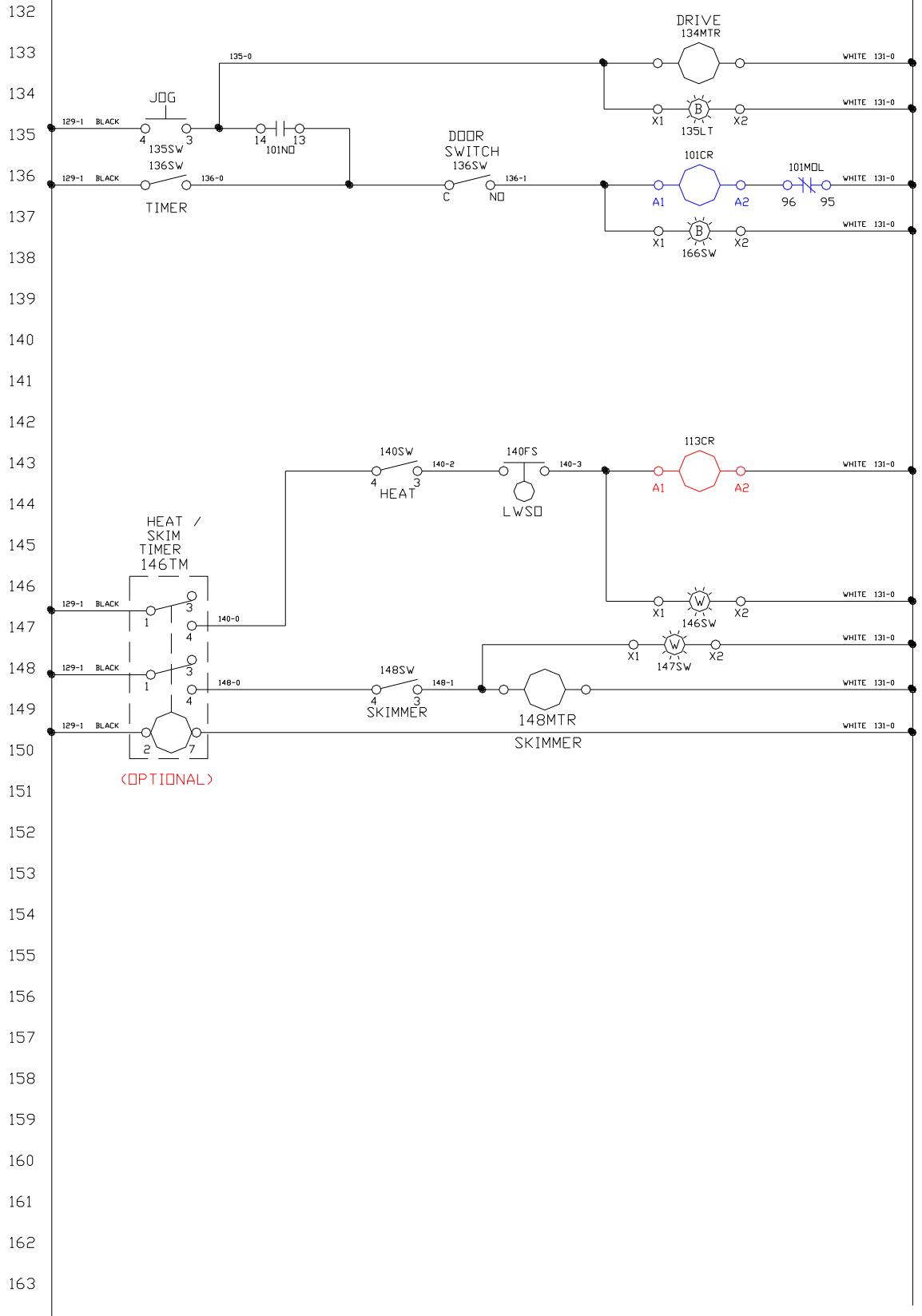

WARRANTY POLICY

ONE-YEAR LIMITED WARRANTY

WASHER PARTS AND CABINET ARE WARRANTED TO BE FREE OF DEFECTS IN MATERIAL AND WORKMANSHIP FOR A PERIOD OF ONE YEAR FROM THE DATE OF SHIPMENT. NORMAL WEAR PARTS, AND DAMAGE RESULTING FROM NEGLIGENCE, CARELESSNESS, ABUSE, MISUSE, OR ABNORMAL USE WHICH IMPAIR PROPER OPERATION ARE NOT COVERED UNDER WARRANTY.

LIABILITY LIMITATION

LIABILITY FOR CONSEQUENTIAL OR INCIDENTAL DAMAGES IS EXPRESSLY DISCLAIMED TO THE EXTENT ALLOWABLE UNDER APPLICABLE LAW.

INTERCONT'S FACTORY CANNOT BE HELD RESPONSIBLE FOR INJURY, EITHER PERSONAL OR PROPERTY SUSTAINED THROUGH WASHER OPERATION OR USAGE.

WARRANTY DISCLAIMER

WARRANTY IS EXPRESSLY MADE IN LIEU OF ANY AND ALL OTHER WARRANTIES EXPRESSED OR IMPLIED INCLUDING MERCHANTABILITY OR FITNESS FOR A PARTICULAR PURPOSE.

WASHER SUITABILITY

QS AND INTERCONT DO NOT GUARANTEE WASHER COMPLIANCE WITH LOCAL, STATE, OR NATIONAL CODES OR REGULATIONS AND CANNOT BE HELD RESPONSIBLE FOR APPLICATION, INSTALLATION, OR CLEANING SOLUTION DISPOSAL.

RETURN AUTHORIZATION

RETURN AUTHORIZATION IS REQUIRED TO RETURN PARTS OR WASHER TO FACTORY FOR WARRANTY CONSIDERATION.

WARRANTY POLICY INCLUDES REPAIR OR REPLACEMENT AND IS CONTINGENT UPON FACTORY INSPECTION AND JUDGMENT.

DEFECTIVE PARTS AND/OR WASHER SHOULD BE RETURNED TO FACTORY ADDRESS VIA PREPAID FREIGHT.

WASHER SHOULD BE EMPTY, WITH CLEANED OUT TANK, PALLETIZED WITH SHRINKWRAP/CARDBOARD PROTECTION, AND SECURED WITH STRAPS OR ROPE FOR SHIPMENT.